

Monroe County, IN
1440 W Estate DR
39 DEGREES NORTH (855) GIS-3939

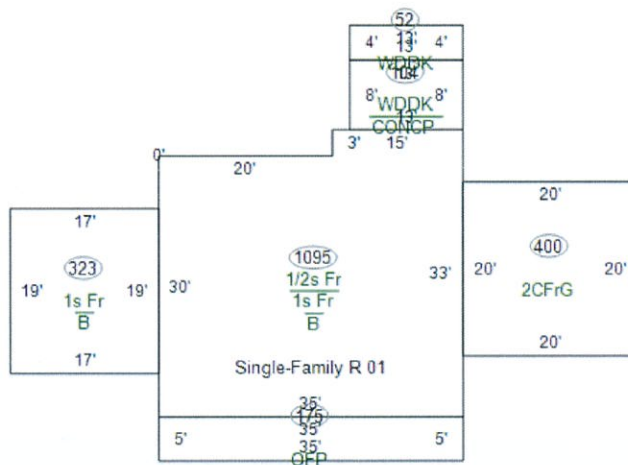

BLOOMINGTON_199178



Parcel Information

Owner Name	Peach, Richard J & Mary E
Owner Address	1440 W Estate Drive Bloomington, In 47403
Parcel Number	53-08-20-204-013.000-008
Alt Parcel Number	014-07856-69
Property Address	1440 W Estate Dr, Bloomington, In 47403-9064
Property Class Code	510
Property Class	1 Family Dwell - Platted Lot
Neighborhood	Eagleview - A, 53008071-008
Legal Description	014-07856-69 EAGLEVIEW SEC 3 PH 1 LOT 69

Taxing District

Township	Perry Township
Corporation	Monroe County Community
Taxing District Name	Perry Township
Taxing District Number	008

Land Description

Land Type	Acreage	Dimensions
9	0.39	

Transfer of Ownership

Date	Name	Buyer	Document	Deed Type	Sale Price
1900-01-01	Unknown			Wd	
2003-06-23	Gredy, Rebecca		0	Cw	
2019-04-16	Peach, Richard J & Mary E		2019004951	Wd	\$361,900.00

Valuation Record

Assessment Date	Reason for Change	Land	Improvements	Total Valuation
2023-04-06	Annual Adjustment	\$77,400.00	\$416,300.00	\$493,700.00
2022-04-08	Annual Adjustment	\$71,600.00	\$397,800.00	\$469,400.00
2021-03-19	Annual Adjustment	\$50,800.00	\$318,000.00	\$368,800.00
2020-03-20	Annual Adjustment	\$50,800.00	\$301,600.00	\$352,400.00
2019-03-12	Annual Adjustment	\$44,300.00	\$217,600.00	\$261,900.00
2018-03-21	Annual Adjustment	\$44,300.00	\$215,300.00	\$259,600.00
2017-03-30	Annual Adjustment	\$44,300.00	\$211,500.00	\$255,800.00
2016-05-02	Annual Adjustment	\$44,300.00	\$205,700.00	\$250,000.00
2015-05-27	General Revaluation	\$44,300.00	\$207,600.00	\$251,900.00
2014-05-15	Annual Adjustment	\$44,300.00	\$207,400.00	\$251,700.00
2013-06-04	Annual Adjustment	\$44,300.00	\$190,800.00	\$235,100.00
2012-06-22	Annual Adjustment	\$44,300.00	\$199,800.00	\$244,100.00
2011-06-08	Annual Adjustment	\$44,300.00	\$198,100.00	\$242,400.00
2010-03-01	Annual Adjustment	\$44,300.00	\$219,000.00	\$263,300.00
2009-03-01	Miscellaneous	\$44,300.00	\$219,000.00	\$263,300.00
2008-03-01	Miscellaneous	\$44,300.00	\$202,200.00	\$246,500.00
2007-03-01	Miscellaneous	\$42,300.00	\$208,900.00	\$251,200.00
2006-03-01	Miscellaneous	\$37,500.00	\$207,200.00	\$244,700.00
2005-03-01	Miscellaneous	\$25,700.00	\$170,200.00	\$195,900.00
2004-03-01	Homestead Change	\$25,700.00	\$170,200.00	\$195,900.00
2002-03-01	General Revaluation	\$300.00	\$0	\$300.00
2000-03-01	Miscellaneous	\$0	\$0	\$0

Sales

Sale Date	Sale Price	Buyer Name	Seller Name
2019-04-12	\$361,900.00	Richard J Peach	Rebecca Gredy

Public Utilities

Water	N
Sewer	N
Gas	N
Electricity	N
All	Y

Exterior Features

Exterior Feature	Size/Area
Patio, Concrete	104
Porch, Open Frame	175
Wood Deck	52
Wood Deck	104

Special Features

Description	Size/Area
-------------	-----------

Summary of Improvements

Buildings	Grade	Condition	Construction Year	Effective Year	Area
Single-family R 01	B-1	A	2004	2004	3,931

Single-Family R 01

Accommodations

Bed Rooms	3
Finished Rooms	5

Plumbing

Full Baths	2
Full Baths Fixtures	6
Half Baths	1
Half Baths Fixtures	2
Kitchen Sinks	1

Other Residential Dwelling

Heat Type	Central Warm Air
Fireplaces	
Attached Garages	400

Floors

Floor	Construction	Base	Finished
1	Wood Frame	1,418	1,418
1/2	Wood Frame	1,095	1,095
B		1,418	1,418



Tax Bill

Parcel Information

Parcel Number	53-08-20-204-013.000-008
Tax ID	014-07856-69
Owner Name	Peach, Richard J & Mary E
Owner Address	1440 W Estate Drive Bloomington, In 47403
Legal Description	014-07856-69 EAGLEVIEW SEC 3 PH 1 LOT 69

2023 PAY 2024

Deductions

Type	Amount
Standard Hmst	\$48,000.00
Supplemental Hsc	\$178,280.00

Payments

Tax Set	Charge Type	Total Charge	Posted Pay.	Balance Due
Perry Township	Spring Other Assessment Tax	\$37.88	\$0	\$0
Perry Township	Fall Other Assessment Tax	\$37.88	\$0	\$0
Perry Township	Year Total Other Assessment Tax	\$75.76	\$0	\$0

2022 PAY 2023

Deductions

Type	Amount
Standard Hmst	\$45,000.00
Supplemental Hsc	\$148,540.00

Payments

Tax Set	Charge Type	Total Charge	Posted Pay.	Balance Due
Perry Township	Spring Installment	\$1,939.82	\$1,977.70	\$0
Perry Township	Spring Other Assessment Tax	\$37.88	\$0	\$0
Perry Township	Fall Installment	\$1,939.82	\$1,977.70	\$0
Perry Township	Fall Other Assessment Tax	\$37.88	\$0	\$0
Perry Township	Year Total	\$3,879.64	\$3,955.40	\$0
Perry Township	Year Total Other Assessment Tax	\$75.76	\$0	\$0

2021 PAY 2022**Deductions**

Type	Amount
Standard Hmst	\$45,000.00
Supplemental Hsc	\$113,330.00

Payments

Tax Set	Charge Type	Total Charge	Posted Pay.	Balance Due
Perry Township	Spring Installment	\$1,494.76	\$1,532.64	\$0
Perry Township	Spring Other Assessment Tax	\$37.88	\$0	\$0
Perry Township	Fall Installment	\$1,494.76	\$1,532.64	\$0
Perry Township	Fall Other Assessment Tax	\$37.88	\$0	\$0
Perry Township	Year Total	\$2,989.52	\$3,065.28	\$0
Perry Township	Year Total Other Assessment Tax	\$75.76	\$0	\$0

2019 PAY 2020**Deductions**

Type	Amount
Mortgage	\$3,000.00
Disabled	\$12,480.00
Standard Hmst	\$45,000.00
Supplemental Hsc	\$75,915.00

Payments

Tax Set	Charge Type	Total Charge	Posted Pay.	Balance Due
Perry Township	Spring Installment	\$812.04	\$829.62	\$0
Perry Township	Spring Other Assessment Tax	\$17.58	\$0	\$0
Perry Township	Fall Installment	\$812.04	\$829.62	\$0
Perry Township	Fall Other Assessment Tax	\$17.58	\$0	\$0
Perry Township	Year Total	\$1,624.08	\$1,659.24	\$0
Perry Township	Year Total Other Assessment Tax	\$35.16	\$0	\$0

2018 PAY 2019

Deductions

Type	Amount
Mortgage	\$3,000.00
Disabled	\$12,480.00
Standard Hmst	\$45,000.00
Supplemental Hsc	\$75,110.00

Payments

Tax Set	Charge Type	Total Charge	Posted Pay.	Balance Due
Perry Township	Spring Installment	\$811.83	\$1,658.82	\$-829.41
Perry Township	Spring Other Assessment Tax	\$17.58	\$0	\$0
Perry Township	Fall Installment	\$811.83	\$0	\$0
Perry Township	Fall Other Assessment Tax	\$17.58	\$0	\$0
Perry Township	Year Total	\$1,623.66	\$1,658.82	\$0
Perry Township	Year Total Other Assessment Tax	\$35.16	\$0	\$0

Overlay Report

Overlay by Landuse and Soil

PIN 18	53-08-20-204-013.000-008			
Total Acreage	0.802			
Total Adj. Acreage	0.780			
Soil Type	Land Use Code	Land Type	GIS Acreage	Adj. Acreage
Crc	Unk		0.000	0.000
	4	Tillable Land	0.000	0.000
Crc	4	Tillable Land	0.401	0.390
	82	Agric Support-public Road	0.401	0.390
Crc	82	Agric Support-public Road	0.000	0.000

Overlay by Landuse

PIN 18 53-08-20-204-013.000-008
Total Acreage 0.401
Total Adj. Acreage 0.390

Land Use Code	Land Type	GIS Acreage	Adj. Acreage
4	Tillable Land	0.401	0.390
82	Agric Support-public Road	0.000	0.000
Unk		0.000	0.000